

## Fitting instruction – WAS-017

AUDI A3 8V (2012-), VW GOLF MK7 GTI  
2015 • Present

Front tubular wishbone (right/left)



Suppresses:

- 5Q0 407 151 J / 5Q0 407 152 J (left/right)
- 5Q0 407 151 K / 5Q0 407 152 K (left/right)
- 5Q0 407 151 M / 5Q0 407 152 M (left/right)
- 5Q0 407 151 R / 5Q0 407 152 R (left/right)

## List of Contents

1. For scope of delivery	1
2. Fitting instructions	1
3. Safety notes	1
4. Conditions	1
5. Work tips	1
6. Front tubular wishbone assembly (right)	2
7. Modification of xenon range sensor	3
8. Setting up front suspension.	3
9. Front tubular wishbone setting up	4

## 1. For scope of delivery

Designation	Part number	Num. of items
Front tubular wishbone	WAS-016-A1	2
Aluminum bearing carrier	WAS-010-A2	2
Pivot pin	WAS-010-12	2
Pivot pin spacer	WAS-010-13	2
Bolt M6x16		2
Bolt M10x45	7 / 8	6
Bolt M12x45	9	2
Nut M10	10	10

## 2. Fitting instructions

- All work steps must be performed in accordance with the listed safety notes and instructions.
- For all bolts and nuts use specified tightening torque as said in your car manual.
- Provided nuts are disposable (distorted thread locknut). One time use.

## 3. Safety notes

### CAUTION

Risk of accident due to high weight of elements.

### CAUTION

Risk of injury from dirt particles. Risk of eye injuries.

- Always wear safety goggles.

## 4. Conditions

- Ignition switched off.
- Second mechanic available.

## 5. Work tips

- Parts of the following description only indicate the procedure on one side of the vehicle. In this case proceed in basically the same way on the opposite side of the vehicle.

- If bolts and nuts are difficult to loosen, spray them with rust remover.

## 6. Front tubular wishbone assembly (right)

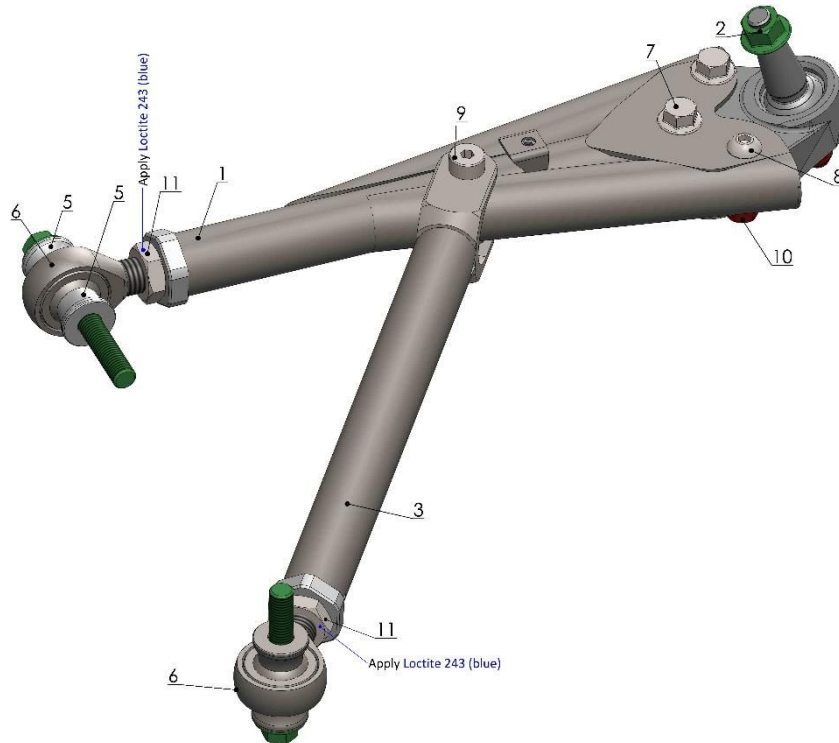

*Figure 1 Front tubular wishbone assembly  
(OEM parts – green, one time use only parts – red).*

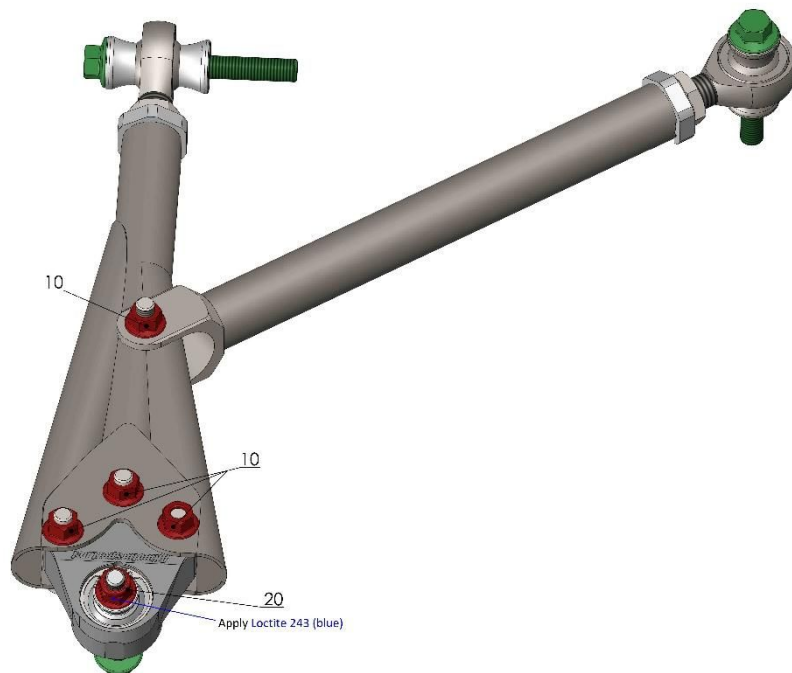

Figure 2 Front tubular wishbone assembly  
(OEM parts – green, one time use only parts – red).

## 7. Modification of xenon range sensor

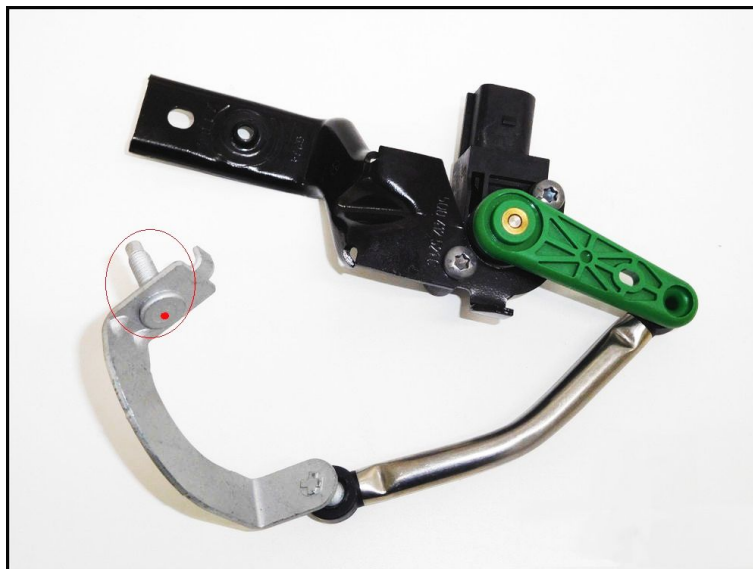

Figure 3 Xenon range sensor. Marked bolt which need to be removed.

To install xenon range sensors on tubular wishbones, it must be modified permanently. To do so, you have to drill the screw (Marked red

on Figure 3). Firstly punch the screw in a center (Red dot on Figure 3) and then drill it with a small drill bit.

## 8. Setting up front suspension.

To achieve the best kinematics of front suspension, you should use the sleeves included in the kit. They change the kinematics of the suspension, changing the position of the turnover centers of the components. However, to get it, you should have to install our front tubular subframe ([WAS-570](#)).

Install provided spacers in places shown on the picture below. Then reinstall sway bar and steering gear using provided bolts (4x M8x80, 2x M10x80).

After that make sure to install wishbones using second row of holes in front mount and insert wishbone spacers under the rod end.

The location of sleeve spacers is shown in the picture below (Figure 3).

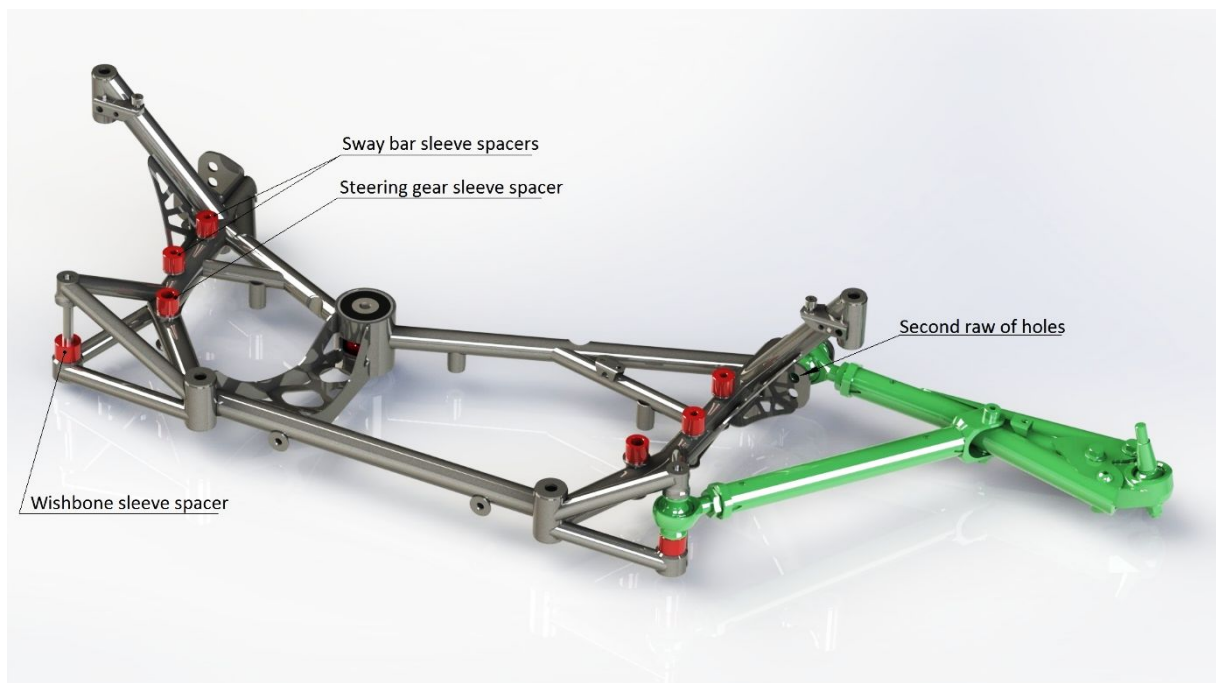
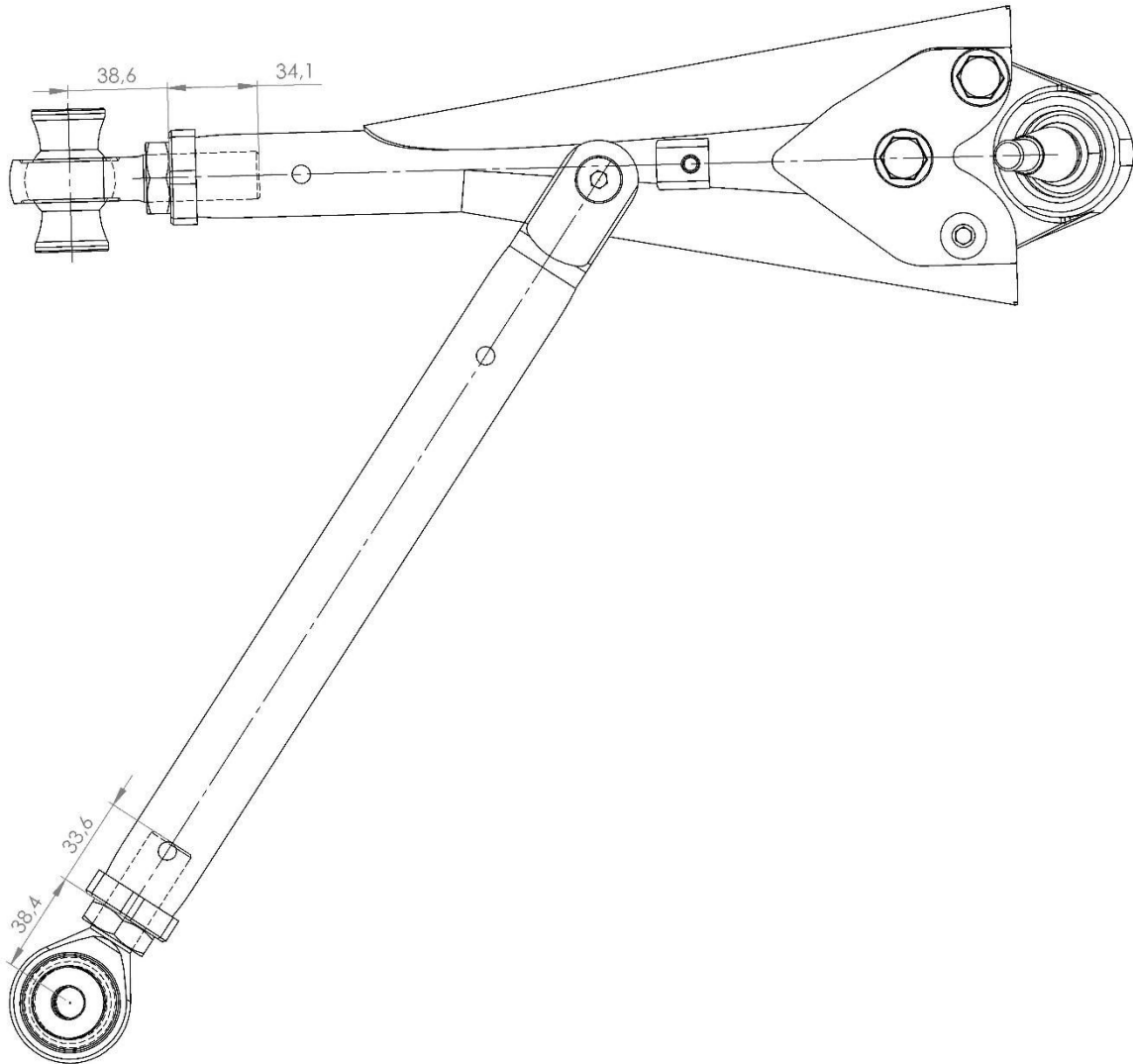

Figure 4 Tubular subframe with spacers and tubular wishbone assembly.

## 9.

## 10. Front tubular wishbone setting up

- a. Before installing wishbones on car, make sure you set up the correct length of rod ends to get OEM length of wishbones as a starting point for desired camber and caster setup (Figure 5). Set rod ends perpendicular to wishbone plane.
- b. Install front part of wishbone inside subframe, then match rear part.
- c. Tighten OEM bolts.
- d. Install pivot pin inside knuckle and tighten nut (Number 20 on Figure 2). **Secure thread with Loctite 243 (Blue). Tightening torque 60 Nm.**
- e. After initial camber and caster alignment you can change the position of a wheel for an extra camber or caster values. Make sure the minimum screwing value of rod ends should be 18 mm (approximately 12 full turns). Use caliper to measure the threaded part of rod end from top of it to nut and then screw it inside wishbone.
- f. When desired alignment setup is reached **secure thread with Loctite 243 (Blue)** on nuts on both rod ends (2 x Number 11 on Figure 1). **Tightening torque 100 Nm**
- g. Tighten nuts (Number 10 on Figure 2). **Tightening torque 70 Nm.**
- h. Install xenon range sensor arm on wishbone with provided M6x16 bolt.
- i. After test drive check all nuts and bolts.



*Figure 5 Front tubular wishbone assembly (top view) with rod ends setting OEM length. Used as a starting point for setting up desired caster and camber settings.*