

## Fitting instruction – SBK-016

AUDI 8J TTRS, TTS, TT  
2007 ► 2014

Rear billet aluminum subframe bushes.



Suppresses:

- 1K0 505 145 J (front)
- 5Q0 505 145 D (front)
- 1K0 505 145 K (rear)
- 5Q0 505 145 E (rear)

## List of Contents

1. For scope of delivery	3
2. Work tips	3
3. Safety notes	3
4. Conditions	3
5. Removing OEM bushes	4
6. Installing billet aluminum bushes	5

## 1. For scope of delivery

Designation	Part number	Num. of items
Lower bush	SBK-016-1	4
Rear upper bush	SBK-016-2	2
Front upper bush	SBK-016-3	2

## 2. Work tips

- All work steps must be performed in accordance with the listed safety notes and instructions.
- For all bolts and nuts use specified tightening torque as said in your car manual.
- Provided nuts are disposable (distorted thread locknut). One time use.
- Parts of the following description only indicate the procedure on one side of the vehicle. In this case proceed in basically the same way on the opposite side of the vehicle.
- If bolts and nuts are difficult to loosen, spray them with rust remover.

## 3. Safety notes

CAUTION	CAUTION
Risk of accident due to high weight of elements.	Risk of injury from dirt particles. Risk of eye injuries. <ul style="list-style-type: none"><li>• Always wear safety goggles.</li></ul>

## 4. Conditions

- Ignition switched off.
- Second mechanic available.
- Subframe mounting bolts need to be replaced with new ones.

## 5. Removing OEM bushes

Lift car up and disassemble rear suspension. Unscrew all suspension links from uprights and remove rear exhaust part. Next step is to remove rear differential. After all you can unscrew four mounting bolts (Number 4 on Figure 1) of support frame and remove it from the car.

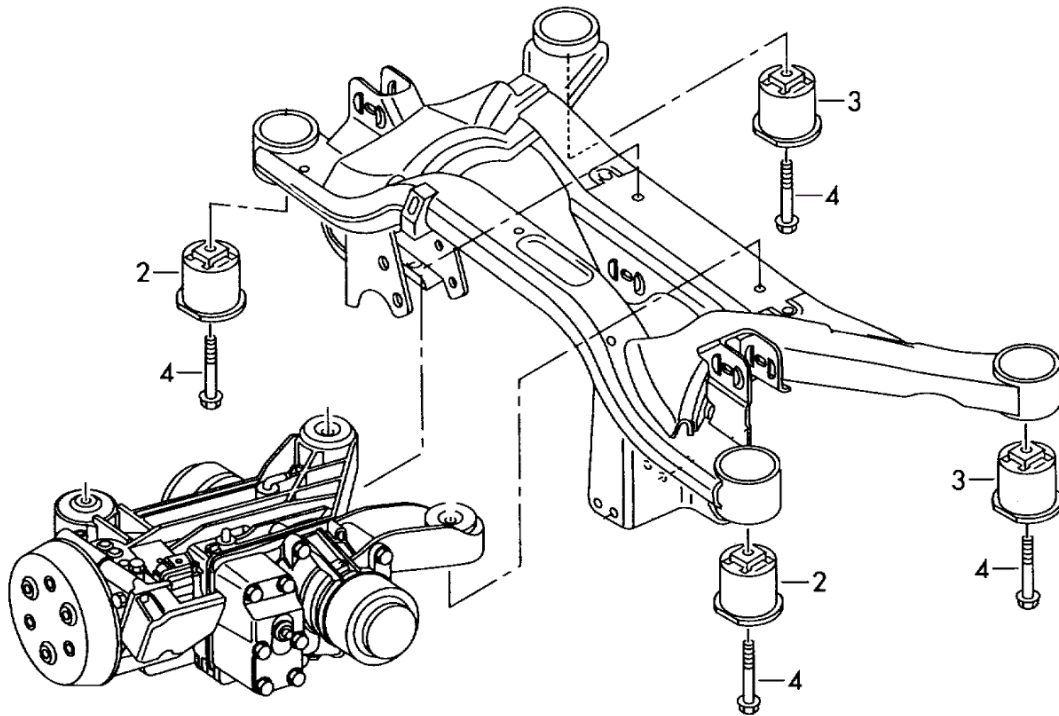

*Figure 1 Rear support frame with OEM bushes.*

To remove OEM bushes from rear subframe use a press. Securely fasten support frame and press firmly from the top to remove every bush (Number 2, 3 on Figure 1). Clean inside of the hole and make sure an edge does not have any damage. You can lubricate inside of the hole with a small amount of grease (not provided).

## 6. Installing billet aluminum bushes

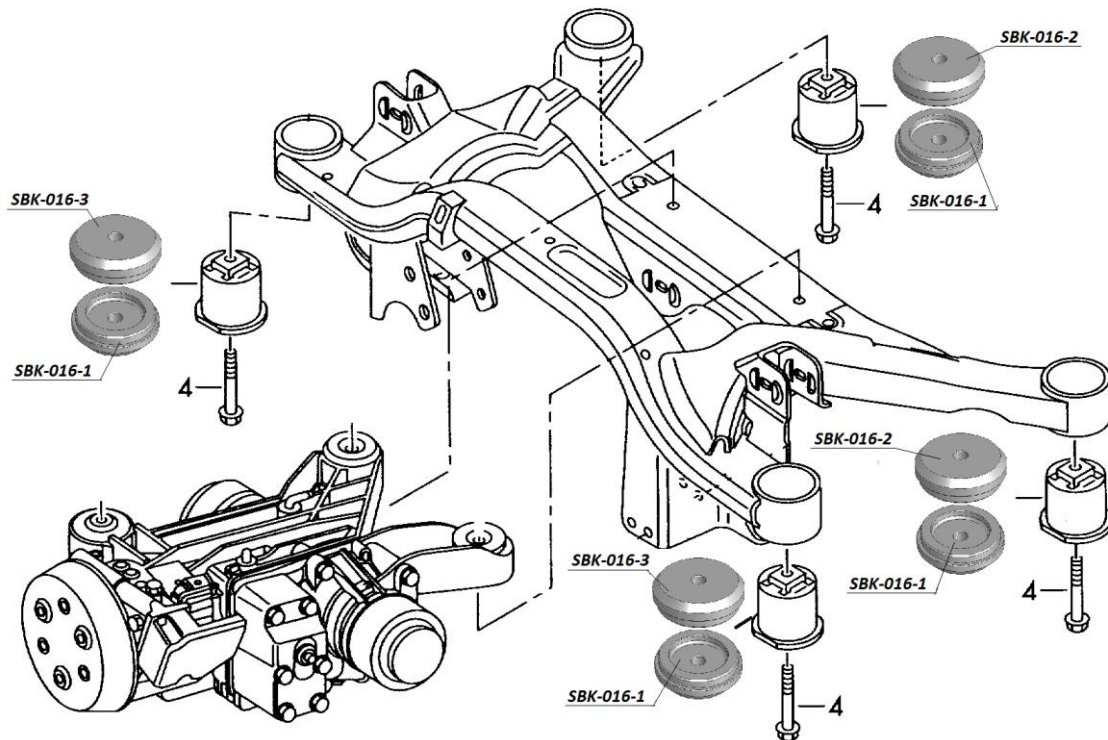

Figure 2 Rear support frame with billet aluminum bushes.

Place billet aluminum bushes in right places (Figure 2) and screw all mounting bolts. Tighten OEM bolts (Number 4 on Figure 2) to OEM tightening torque (110 Nm + 90°). The remaining installation steps are carried out in the reverse sequence. After installation the camber and toe settings must be checked using wheel alignment equipment.

Tightening torques:

Subframe to body (use new bolts)

110 Nm + 90°

Propshaft to final drive

60 Nm