

## Fitting instruction – WAS-017

AUDI A3 8V (2012+), AUDI TT 8S (2014+), VW GOLF MK7 (2012-2019),  
Seat Leon 5F (2012+)

### Front tubular wishbone (right/left)



#### Suppresses:

- 5Q0 407 151 J / 5Q0 407 152 J (left/right)
- 5Q0 407 151 K / 5Q0 407 152 K (left/right)
- 5Q0 407 151 M / 5Q0 407 152 M (left/right)
- 5Q0 407 151 R / 5Q0 407 152 R (left/right)
- 8S0 407 151 B (left/right)
- 8S0 407 151 D (left/right)

## List of Contents

|     |   |   |
|-----|---|---|
| 1.  | For scope of delivery                   | 1 |
| 2.  | Fitting instructions                    | 1 |
| 3.  | Safety notes                            | 1 |
| 4.  | Conditions                              | 2 |
| 5.  | Work tips                               | 2 |
| 6.  | Front tubular wishbone assembly (right) | 2 |
| 7.  | Modification of xenon range sensor      | 3 |
| 8.  | Setting up front suspension.            | 4 |
| 9.  | Front tubular wishbone setting up       | 5 |
| 10. | OEM torque specification table          | 8 |

## 1. For scope of delivery

Table 1 Provided parts

| Designation                   | Part       | Torque      | Quantity |
|-------------------------------|------------|-------------|----------|
| Front tubular wishbone        | 1          | -           | 2        |
| Rear aluminum wishbone mount  | 4          | -           | 2        |
| Aluminum bearing carrier      | WAS-010-07 | -           | 2        |
| Pivot pin                     | WAS-010-12 | -           | 2        |
| Pivot pin spacer              | WAS-010-13 | -           | 2        |
| Steering gear sleeve spacer   | WAS-017-M1 | -           | 2        |
| Sway bar sleeve spacer        | WAS-011-M2 | -           | 4        |
| Bolt M8x80 for anti-roll bar  | -          | 20 Nm + 90° | 4        |
| Bolt M10x45                   | 8          | 75 Nm       | 4        |
| Bolt M12x90 for steering gear | -          | 50 Nm + 90° | 2        |
| Socket button bolt M10x45     | 9          | 75 Nm       | 2        |
| Shoulder bolt M10/12x45       | 11         | 75 Nm       | 2        |
| Nut M10                       | 12         | 75 Nm       | 6        |
| Nut M10                       | 20         | 60 Nm       | 2        |

## 2. Fitting instructions

- Please follow install instructions when installing this parts. Failure to follow the instructions can result in part malfunction and serious accident.
- All work steps must be performed in accordance with the listed safety notes and instructions.
- For all bolts and nuts use specified tightening torque provided bellow or as said in your car manual. **DO NOT OVERTORQUE!**
- Parts of the following description only indicate the procedure on one side of the vehicle. In this case proceed in basically the same way on the opposite side of the vehicle.

## 3. Safety notes

|  |   |
|--|---|
| <b>CAUTION</b>   | <b>CAUTION</b>  |
| Risk of accident due to high weight of elements.   | All VERKLINE products are intended for Off Road Use Only. |
| <b>CAUTION</b>   |   |
| Risk of injury from dirt particles. Risk of eye injuries.<br>Always wear safety goggles. |   |

## 4. Conditions

- Ignition switched off.
- Second mechanic available.

## 5. Work tips

- Provided nuts are disposable (distorted thread locknut).  
**ONE TIME USE.**
- It is very important to use Loctite 243 (Blue) to lock parts described in the instructions below.
- If bolts and nuts are difficult to loosen, spray them with rust remover.

## 6. Front tubular wishbone assembly (right)

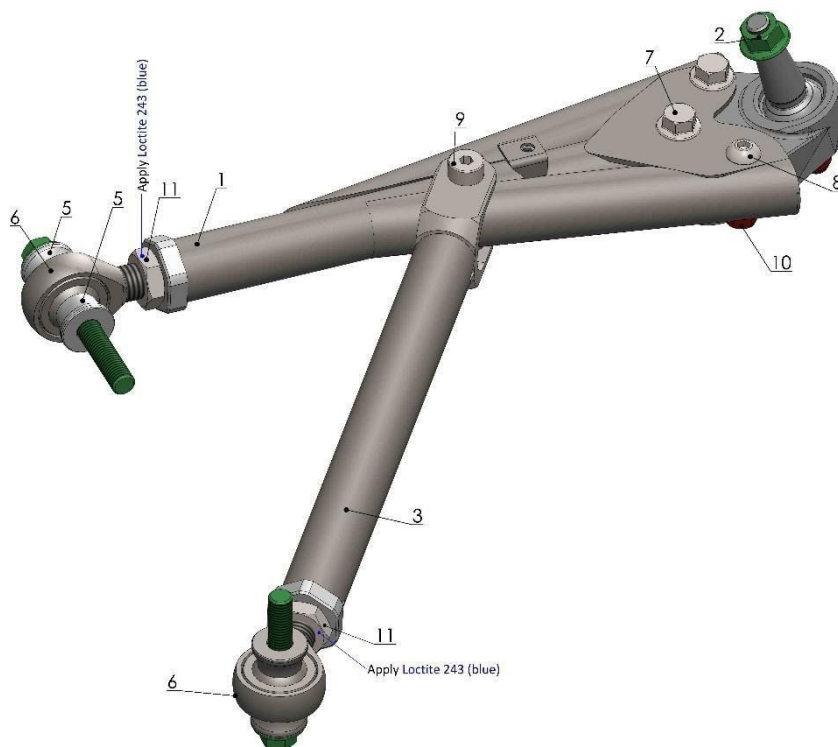

Figure 1 Front tubular wishbone assembly (OEM parts – green, one time use only parts – red).

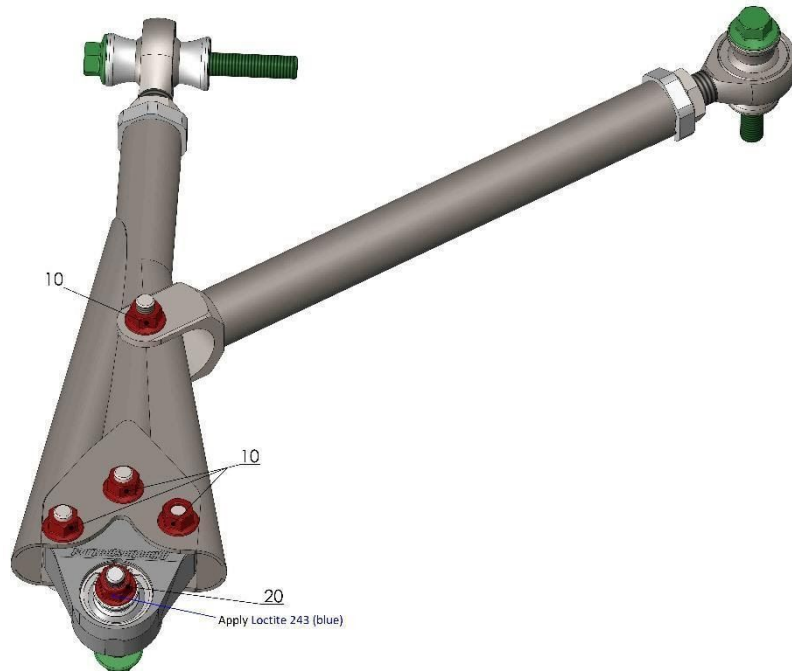

Figure 2 Front tubular wishbone assembly (OEM parts – green, one time use only parts – red).

## 7. Modification of xenon range sensor

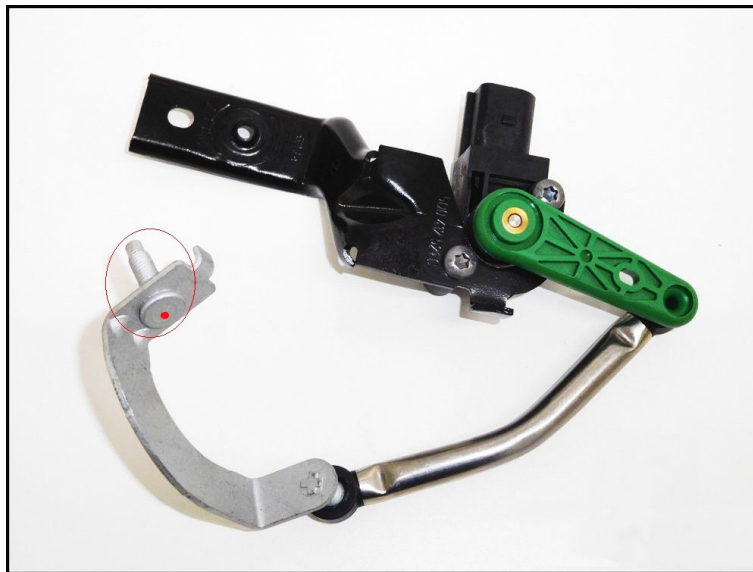

Figure 3 Xenon range sensor. Marked bolt which need to be removed.

To install xenon range sensors on tubular wishbones, it must be modified permanently. To do so, you have to drill the screw (Marked red on Figure 3). Firstly punch the screw in a center (Red dot on Figure 3) and then drill it with a small drill bit.

## 8. Setting up front suspension.

To achieve the best kinematics of front suspension, you should use the sleeves included in the kit. They change the kinematics of the suspension, changing the position of the turnover centers of the components. However, you need to install our front tubular subframe also ([WAS-570](#)).

Install provided spacers in places shown on the picture below. Then reinstall sway bar and steering gear using provided bolts (4x M8x80, 2x M12x80). Do not worry, if one of the sleeves is loose, it has been done to allow easier installation.

After that make sure to install wishbones using second row of holes in front mount and insert wishbone spacers under the rod end.

The location of sleeve spacers is shown in the picture below (Figure 4).

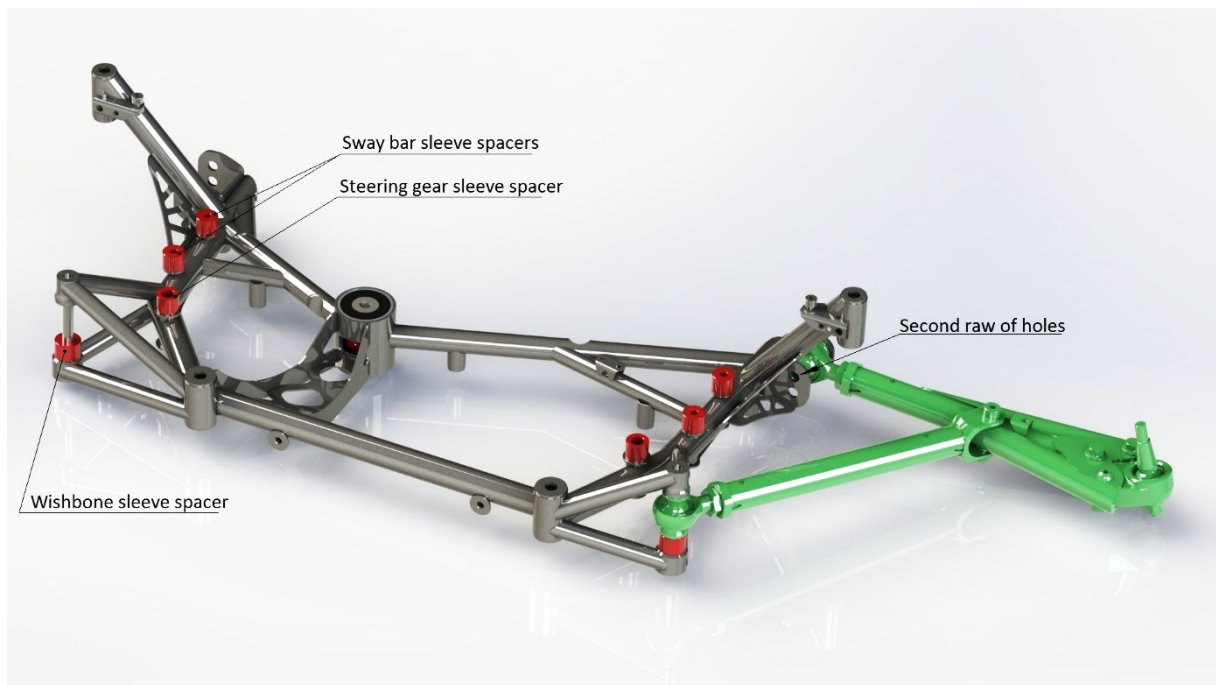

Figure 4 Tubular subframe with spacers and tubular wishbone assembly.

After all, you should remove steering gear seal ring (part number 5Q0 423 187 F). To do so, pull the ring gently and remove it. Then, secure marked plane (Figure 5) with a small amount of sealant.

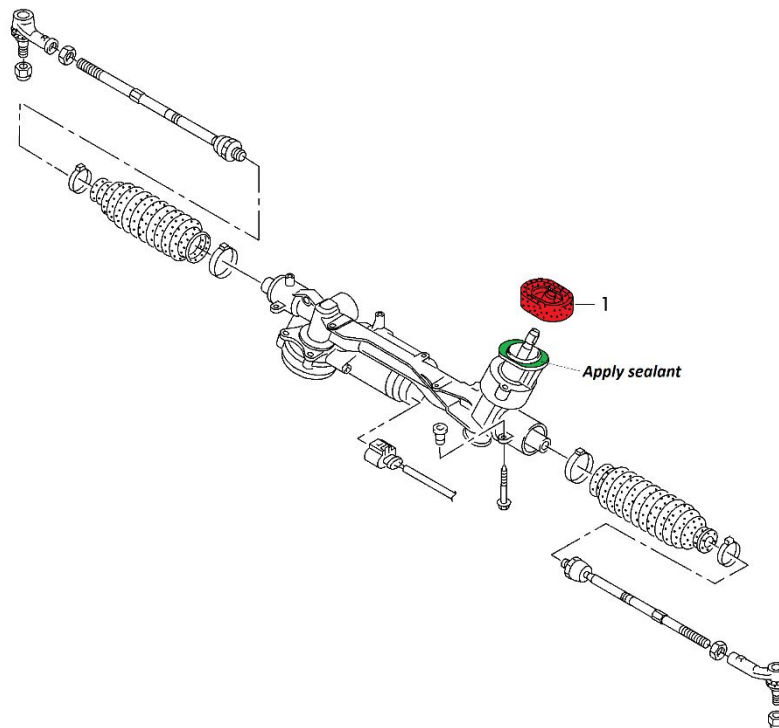

Figure 5 Steering gear seal ring (number 1), and place where apply sealant.

## 9. Front tubular wishbone setting up

- Before attempting to work, secure rod ends with provided dust boots. You can use bent external seger pliers to do it.



- Before installing wishbones on car, make correct length of rod ends to get OEM length of wishbones. This is preliminary setup. Use Figure 6 or Figure 7 for Audi TT 8S.
- Install rear part of wishbone inside subframe, then match front part.

On vehicles equipped with DSG or Triptronic transmission the LH horizontal bolt cannot be completely removed due to the location of the transmission. You will need to unbolt the pendulum or 'dog bone' mount at the subframe and swing engine forward.

- Install pivot pin inside knuckle and tighten nut (Number 20 on Figure 2). **Secure thread with Loctite 243 (Blue). Tightening torque 60 Nm.**
- After initial camber and caster alignment you can change the position of a wheel for extra camber or caster values by changing the lengths of rod end and aluminum insert position. Make sure the minimum screwing value of rod ends should be 18 mm (approximately 12 full turns). Use caliper to measure the threaded part of rod end from top of it to nut and then screw it inside wishbone.

It is possible to use second set of holes in the aluminum insert to gain extra camber. You have to remove 3 mounting bolts (Number 8,9 on Figure 1), and then pull out a little bit an aluminum bearing carrier. Reinstall the mounting bolts.

If you want to change camber setting, you can remove aluminum insert and rear wishbone bolt. After that, you can rotate the front part of wishbone without having to remove front mounting bolt which will shorten or extend the length of wishbone.

- Tighten OEM bolts (green). Table on the end (Table 2).
- When desired alignment setup is reached, **secure thread with Loctite 243 (Blue)** on nuts on both rod ends (2 x Number 14 on Figure 1).  
**Tightening torque 100 Nm.**
- Tighten nuts (Number 10 on Figure 2).  
**Tightening torque 75 Nm.**
- Install xenon range sensor on wishbone with provided M6x10 bolt.  
**Tightening torque 9 Nm.**
- After doing first 100 km (60 miles) recheck if the bolts are tightened correctly.



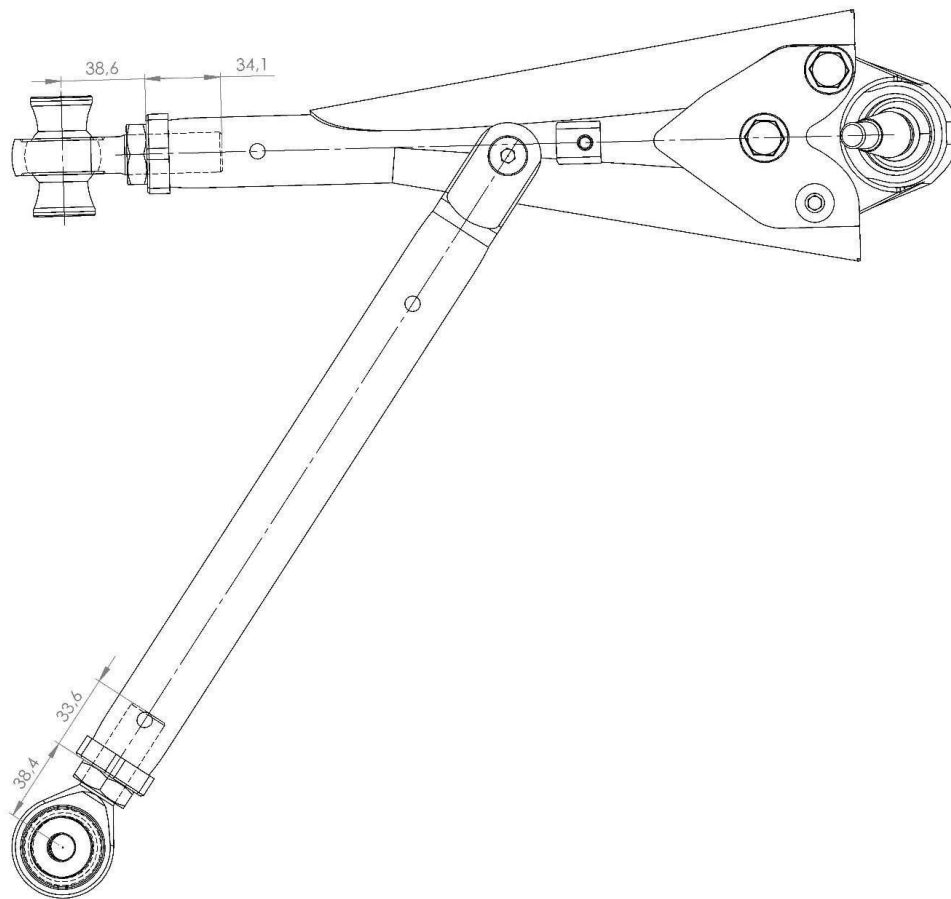

Figure 6 Front tubular wishbone assembly (top view) with rod ends setting OEM length. Used as a starting point for setting up desired caster and camber settings. Audi 8V A3, VW Golf Mk7, Seat Leon 5F. (not for Audi 8S TT - figure 7 below)

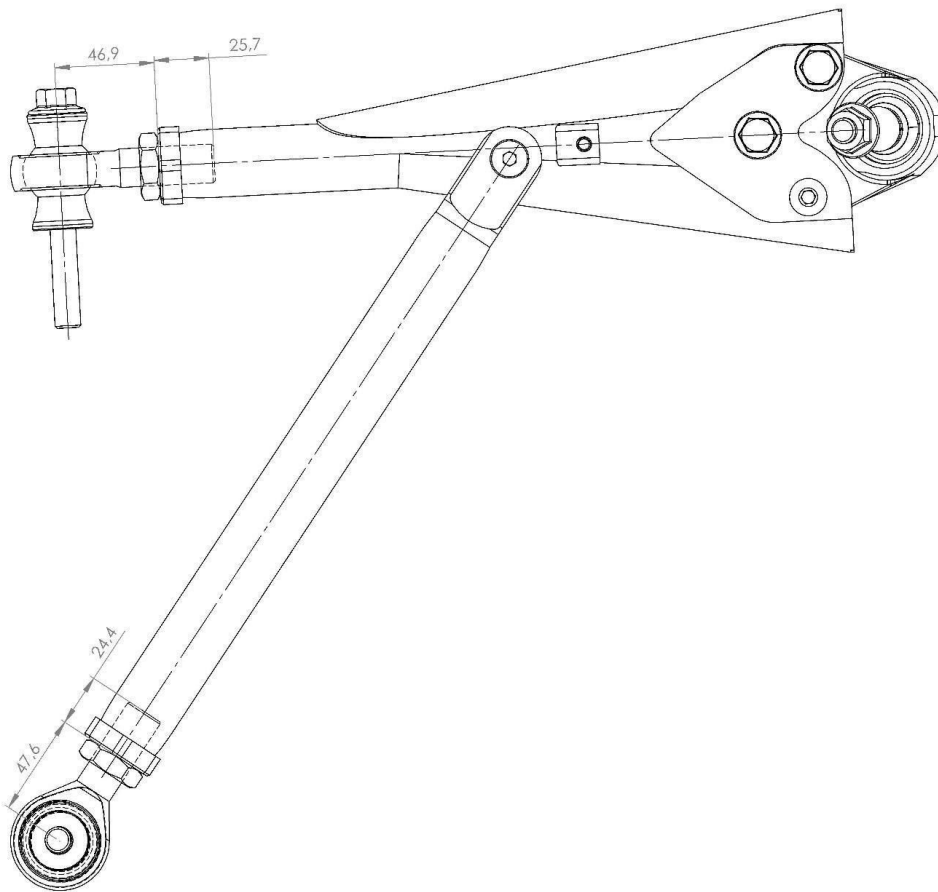

Figure 7 Front tubular wishbone assembly (top view) with rod ends setting OEM length. Used as a starting point for setting up desired caster and camber settings. **Only for Audi 8S TT.**

## 10. OEM torque specification table

Table 2 OEM torque specifications

| Bolt placing   | OEM torque           |
|--|----------------------|
| Front wishbone mount to subframe -<br>M12 x 1,5 x 110  | 70 Nm + 180° further |
| Rear wishbone mount to subframe -<br>M12 x 1,5 x 110   | 70 Nm + 180° further |
| Pivot pin nut to knuckle -<br>M12 x 1,5 (self-locking) | 60 Nm                |

Always renew all mentioned bolts and nuts.  
Always tighten threaded connections in unladen position.